

8 7 6 5 4 3 2 1

D

C

B

A

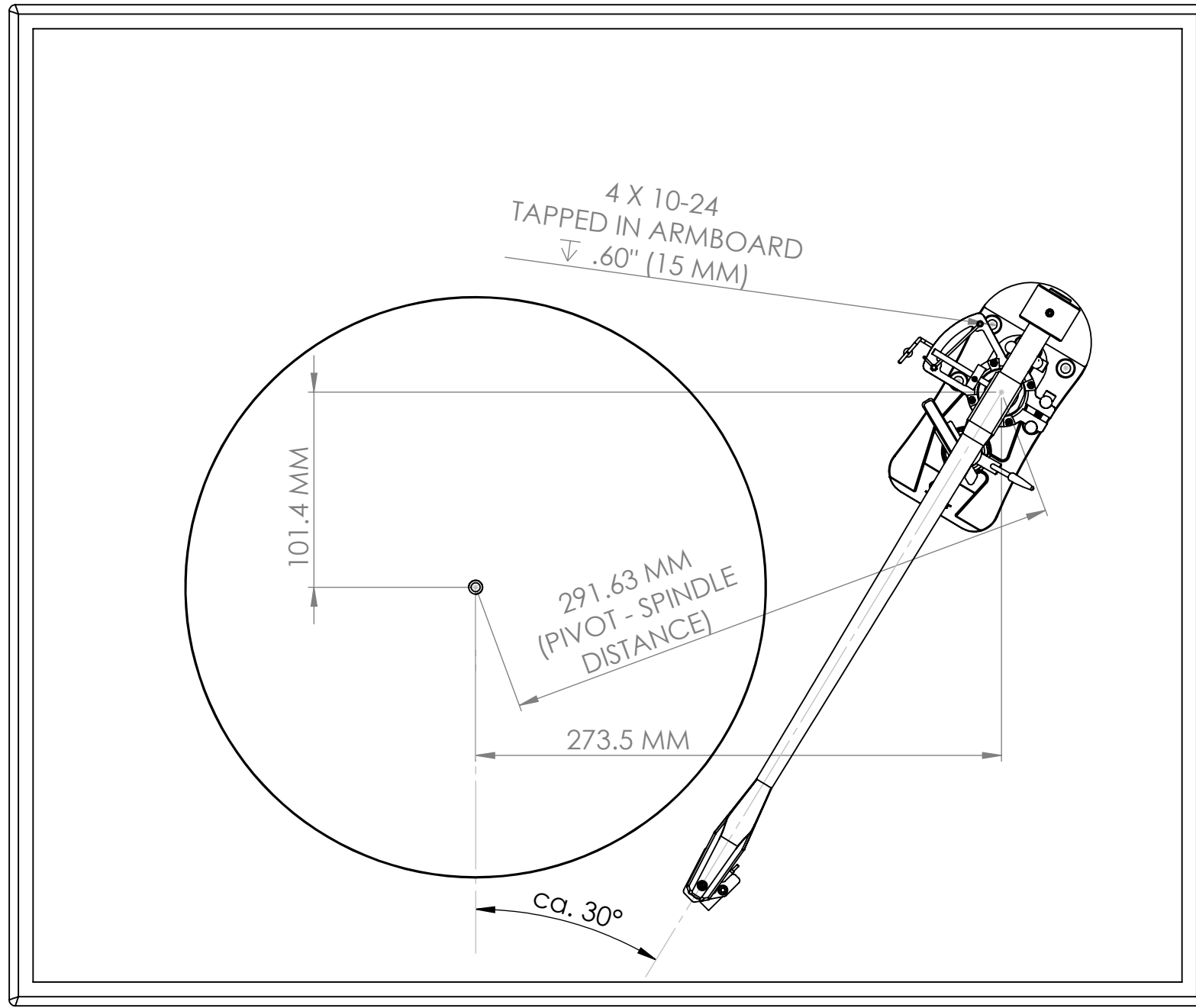

D

C

B

A

PROPRIETARY AND CONFIDENTIAL
 THE INFORMATION CONTAINED IN THIS DRAWING IS THE SOLE PROPERTY OF DURAND TONEARMS LLC. ANY REPRODUCTION IN PART OR AS A WHOLE WITHOUT THE WRITTEN PERMISSION OF DURAND TONEARMS LLC IS PROHIBITED.

COMMENTS:
 ALL DIMENSIONS IN MM, EXCEPT WHERE INDICATED

IF TONEARM POSITION IS MODIFIED, PLEASE ENSURE THAT:
 - PIVOT-SPINDLE DISTANCE REMAINS THE SAME: 291.63 MM
 - ARMWAND CAN COME TO ARM REST CLEAR OF PLATTER
 - ARMWAND DOESN'T RUN OUT OF THE ARM LIFT PLATFORM BEFORE THE END OF THE RECORD

RECOMMENDED DIFFERENCE HEIGHT BETWEEN PLATTER SURFACE AND MOUNTING SURFACE: 28-30 MM
 IF DIFFERENCE IS SMALLER THAN CA. 25 MM, A 1" BLIND HOLE (DEPTH 1") MIGHT NEED TO BE BORED IN MOUNTING SURFACE FOR BEARING COLUMN

| | |
|-------|------------|
| | DATE |
| DRAWN | 9 NOV 2011 |

DO NOT SCALE DRAWING

DURAND TONEARMS LLC

TITLE: **TELOS ON TURNTABLE 2ND POSITION**

| | | |
|----------|----------|-----|
| SIZE | DWG. NO. | REV |
| B | | |

SCALE: 1:10 WEIGHT: SHEET 1 OF 1

8 7 6 5 4 3 2 1